

LUBRICATE ALL SEALS WITH CLEAN HYDRAULIC OIL PRIOR TO ASSEMBLY. DO NOT USE SILICONE BASED LUBRICANTS.

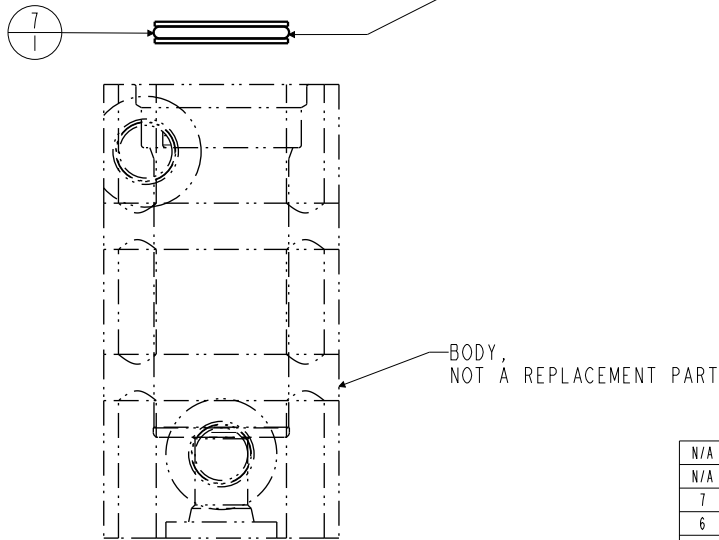

No.	QTY	PART No.	DESCRIPTION	Std Seal Kit	FKM Seal Kit
N/A	N/A	6V200209	SEAL KIT, FKM		NOTED
N/A	N/A	60200210	SEAL KIT, STANDARD	NOTED	
7	1	39H10017	SEAL, T, (13/16 X 5/32 X 1)	X	39V10017
6	1	82031002	GLAND, CYL, 3900 & 17.8 KN		
5	1	82011007	PISTON, CYL, 3900, 1.5 STRK		
4	1	39012008	WIPER, SNAP-IN, (13/16)	X	X
3	1	39011045	SEAL, LL, (13/16 X 1/8 X 1/8 X 1-1/16)	X	39012005
2	1	39001011	O-RING, (-024)	X	39012013
1	1	30601144	PLUG, SOCH, SAE 4		

PARTS LIST

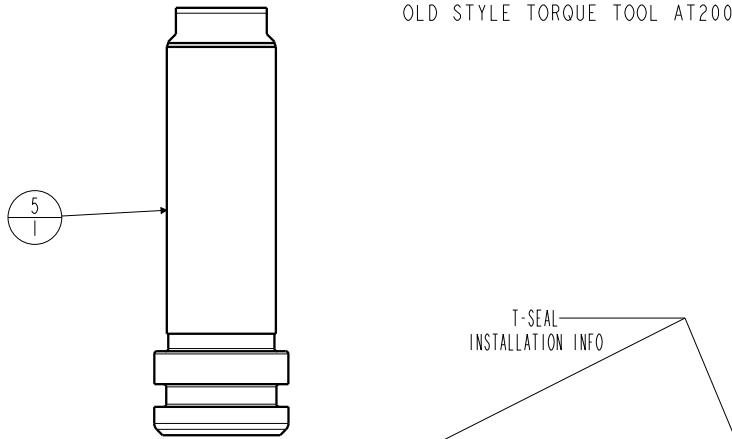
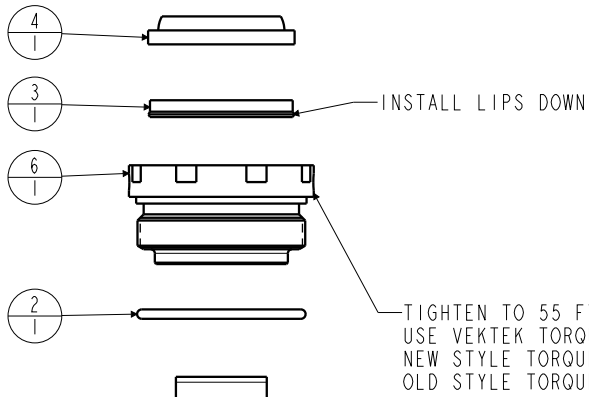

VEKTEK, INC.
1334 E. SIXTH AVE. P.O. BOX 625
EMPORIA, KS. 66801 U.S.A.

ASSEMBLIES AFFECTED
20121004
20121004F

PARTS LIST, ASSY, CYL, BB, 3900, 1.5 STRK, DA

SIZE
A PL2088

REV
H

FORM FEG035_PL_ASIZE, REV. B

H	5499	RELEASE	NPETERS	9/23/24
REV	IN ACCORDANCE WITH ECN	EFFECTIVE DATE	REVISED BY	DATE
DRW BY:	JACOB	DRAWING STATUS: Released		
DATE:	06/24/96	PRODUCTION APPROVED FOR RELEASED STATUS ONLY		

SHEET 1 OF 1